

PROJECT:	
CATALOG #	
TYPE:	DATE:

LED SELECTABLE STRIP FIXTURE

WATT AND CCT SELECTABLE

DESCRIPTION

The LED Strip Fixture is a modern, energy-efficient, linear lighting solution that delivers consistent, high-quality light distribution, minimal energy usage and zero maintenance.

Designed with versatility in mind, the selectable model includes selectable color temperature as well as selectable wattage, allowing the installer to fine-tune the fixture to better meet the needs of the application. Each size offers a range of four color temperature settings (3000K, 3500K, 4000K & 5000K) as well as three unique wattage settings.

Additional accessories can further expand the features of the LED Strip Fixture and make it sensor capable with the additional sensor box (SFASB1) and sensor (SC010) both sold separately.

The fixture is available in either 2', 4' or 8' lengths and can be surface, suspension, or t-grid mounted, either in a single-fixture configuration or as a continuous row to cover more ground from one power source. The lightweight, two-piece design makes installation quick and easy, reducing overall project time.



FEATURES

- 4 Selectable color temperature (3000K, 3500K, 4000K, 5000K)
- 3 Selectable wattage settings
- 145 lumens per watt (lm/W)
- DLC 5.1 Standard & DLC 5.1 Premium
- ETL rated for damp locations
- 10-year warranty
- 100,000-hour rated life (@L70)
- Continuous row mounting (daisy chaining)
- 0-10V dimming (6% minimum)
- Polycarbonate frosted lens with translucent end caps
- Available in 2', 4' and 8' lengths
- Available sensor box (SFASB1) and sensor (SC010) both sold separately.

MOUNTING

- Surface
- Suspension
- Continuous row
- T-grid (standard or angled for wall wash applications)

APPLICATIONS

- Commercial
- Industrial
- Retail
- Manufacturing
- Warehouse
- Display
- Corridors
- Storage
- Stairways
- Garage
- Task Lighting
- Equipment Rooms

CERTIFICATIONS



SPECIFICATIONS

Life (@L70): 100,000 hours

Warranty: 10 years

PERFORMANCE

Operating temp: -4°F – 113°F (-20°C to 45°C)

Efficacy (LPW): 145 LPW

CRI: 80

ELECTRICAL

Input voltage: 120-277V

Input frequency: 50/60Hz

PF: ≥.9

THD: <20

Surge protection: 2KV

Dimming: 0-10V

Minimum dimming: 6% minimum

Aux. Power Tap: N/A

Whip/Cord: No

Sensor: Plug-In (Choice of PIR, Microwave, Bluetooth)

OPTICAL

Beam: 120°

Lens: Polycarbonate Frosted

UGR: N/A

PHYSICAL

Finish: Powder Coat

Color: White

Housing: Painted Steel

INDUSTRY STANDARDS/RATINGS

IP: 20

IK: N/A

Location: Damp

IC: N/A

UL/ETL: ETL

FCC: Yes

RoHS: Yes

DLC: SFS2 - 5.1 Standard

SFS4, SFS8 - 5.1 Premium

DIMENSIONS / WEIGHT

	SIZE	LENGTH	WIDTH	HEIGHT	WEIGHT
SFS8	8'	95.98"	2.93"	3.25"	8.951 lbs
SFS4	4'	48.04"	2.93"	3.25"	5.707 lbs
SFS2	2'	23.97"	2.93"	3.25"	3.586 lbs.

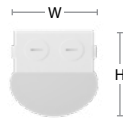

OVERVIEW AND INSTALLATION

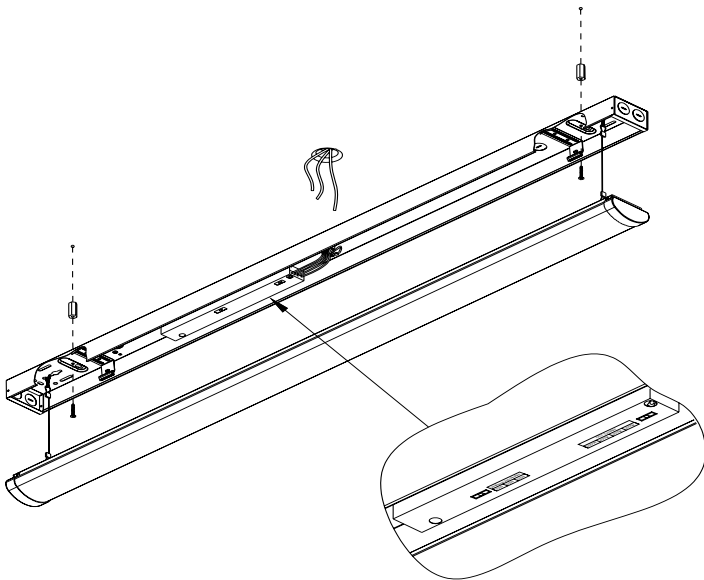

Continuous Mounting

The Strip Fixture can be continuously mounted from one power source. Below are the total units that can be connected per wattage setting.

LENGTH (FT.)	WATTS	MAX CAN BE CONNECTED IN ROW	SFAM06	SFAM07
106	15	53	52*	
80	20	40	39*	
64	25	32	31*	
108	30	27	26	
80	40	20	19	
64	50	16	15	15
128	50	16	15	15
104	60	13		12
88	70	11		10

*For SFS2 (2ft. fixture) use SFAM06 of 4' length, sold separately.

ORDERING

Listed below are the included wattage settings and lumens for each model number.

ORDERING CODE	DESCRIPTION	WATTS	VOLTS	CCT (K)	LUMENS
SFS8	8' Selectable LED Strip Fixture	50 60 70	120-277V	3000K 3500K 4000K 5000K	7250 8700 10150
SFS4	4' Selectable LED Strip Fixture	30 40 50	120-277V	3000K 3500K 4000K 5000K	4350 5800 7250
SFS2	2' Selectable LED Strip Fixture	15 20 25	120-277V	3000K 3500K 4000K 5000K	2175 2900 3625

***Note:** SFS2 DLC 5.1 Standard only. SFS2 Model not compatible with SFASB1, model has no wires and quick connector.



ORDERING CODE	DESCRIPTION	USAGE
SFSAS01	Strip Series Elbow with 3 Wires for Pluggable Sensor	Ordered separately - Can be used with sensors SC005, SC006 and SC008.
SC005	Plug-in PIR Sensor	Enable occupancy sensing and daylight harvesting on pluggable fixtures
SC006	Plug-in Microwave Sensor	Enable occupancy sensing on pluggable fixtures. (MTO Only)
SC008	Plug-in Bluetooth PIR Sensor with IR	This sensor enables wireless control of fixtures, or groups of fixtures, through the LiteSmart mobile app.
SC010	Pluggable Bluetooth PIR Sensor with IR	This sensor enables wireless control of fixture, or groups of fixtures, through the LiteSmart mobile app.
SFASB1	Strip Fixture Sensor Box	Sensor box attachment to enable installation of sensor SC010 to strip fixture.
SCR053	Remote Control	Used (with SC005 and SC006 sensor) to adjust settings after installation
SCR054	Remote Control	Used to Commission LiteTronics "Next Generation" LiteSmart IR-Enabled Sensor.
SFAM02	Suspension Mount Kit	Suspend Strip Fixtures from ceiling surface. Note: Two kits needed for 8' assembly. Cable is 5' in length. Weight rating is 25 lbs.
SFAM06	4' Wire Harness Kit	Connect two or more 4' Strip Fixtures together from one power source.
SFAM07	8' Wire Harness Kit	Connect two or more 8' Strip Fixtures together from one power source.
EB10	10W Emergency Battery Backup	Supplies battery backup to an individual fixture for up to 90 minutes. <u>Must be ordered with EBCM or EBAM indicator module.</u>
EBCM	Ceiling-mounted Indicator Module	This Ceiling-mounted Indicator Module (EBCM) can be used with one of Litetronics' emergency battery backup products (EB10, EB10N or EB20) to provide a visual confirmation of the operational status of the EBB unit. This module is typically used in grid ceiling applications where it is recess mounted in a panel adjacent to the fixture.
EBAM	Adhesive-mounted Indicator Module	This Adhesive-mounted Indicator Module (EBAM) must be used with one of Litetronics' emergency battery backup products (EB10, EB10N or EB20) to provide a visual confirmation of the operational status of the EBB unit. This module is typically used in open ceiling or drywall ceiling applications where the module is applied to the side of the fixture, mounting kit, or a nearby structural element.
LHBAC05	15A 120-277V 5-15P 3-Wires 8' White Cord	
HBAC06	15A 120-277V 3-Wires 10' White Cord WP Twist Connect	
TR01	LED Emergency Light Test Remote	This accessory is required to operate and test the EMBB • Only one remote required per area, building or site as necessary.