

PROJECT:	
CATALOG #	
TYPE:	DATE:

## LED LINEAR HIGH BAY PRO

WATT AND CCT SELECTABLE

### DESCRIPTION

Introducing the LED Linear High Bay Pro, the only High Bay fixture in the industry featuring an All-In-One 120-480V driver. This revolutionary fixture also incorporates 2 beam patterns in one lens. Switch from Standard to Aisle distribution with NO TOOLS.

The LED Linear High Bay Pro goes above and beyond the standards, delivering top-of-the-line efficiency and versatility that results in a truly optimized approach to each application. All Linear High Bay Pro units can accommodate a pluggable sensor that enables increased energy saving features such as occupancy sensing and daylight harvesting, both of which can be adjusted via remote control.

Our Smart Sensor enables the same energy saving features, but can be setup and managed on a group level via the LiteSmart mobile app. The fixture also offers versatility in installation. It comes standard with 10' suspension cables and a 10' cord, making it an easy upgrade from linear fluorescent fixtures. Pendant or surface mounting kit options are available.



### FEATURES

- 3 Selectable watt settings
- Selectable CCT 4000K | 5000K
- Lens rotation feature allows optic lenses to be rotated out without tools
- Rated for damp locations
- DLC 5.1 Premium - High Efficiency up to 163 LPW
- 100,000-hour rated life
- 10-year warranty, no limits on number of hours used
- Optional pluggable sensor enabling occupancy sensing and daylight harvesting (sold separately)
- Compatibility with LiteSmart mobile app
- 120-480V Multi Volt
- 0-10V dimming
- Emergency battery backup available (sold separately)

### MOUNTING

- Suspension Cable V-Hook (Standard)
- Pendant (Optional)
- Surface (Optional)

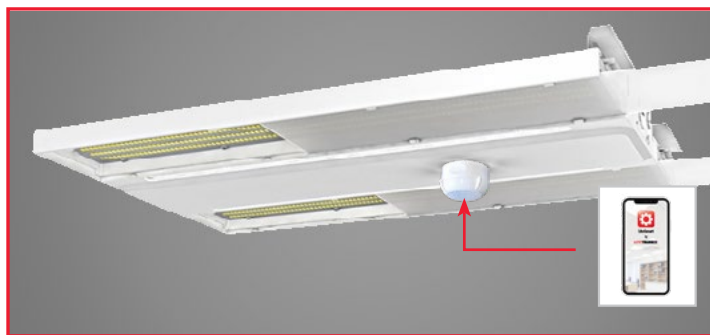

Easy access lens rotation feature, no tools, no screws needed. Pluggable sensor allows for wireless control with the LiteSmart app.

### APPLICATIONS

- Warehouse & storage
- Industrial facilities
- Sports facilities & gyms
- Manufacturing facilities
- Retail centers

### CERTIFICATIONS



## SPECIFICATIONS

**Life (@L70):** 100,000 hours

**Warranty:** 10 years

### PERFORMANCE

**Operating temp:** -40°F to 131°F (-40°C to 55°C)

**Efficacy (LPW)**

**155 LPW**

- LHBP115 - LHBP155 - LHBP195 - LHBP385

**163 LPW**

- LHBP245

**CRI:** 80

### ELECTRICAL

**Input voltage:** 120-480V

**Input frequency:** 50/60Hz

**PF:** ≥.95

**THD:** <20%

**Surge protection:** ANSI C82.77 compliant 10KV

**Dimming:** 0-10VDC ANSI C137.x compliant

**Minimum dimming:** 0% of rated lumen LED drive current

**Aux. Voltage:** Yes

**Whip/Cord:** 10'

**Sensor:** Plug-In (Choice of PIR, Microwave, Bluetooth)

### OPTICAL

**Beam:** 90° x 90° | **Aisle Beam:** 45° x 110°

**Lens:** Polycarbonate Frosted

**UGR:** <28

### PHYSICAL

**Finish:** Powder Coat

**Color:** White

**Housing:** Die Cast Aluminum

### INDUSTRY STANDARDS/RATINGS

**IP:** 20

**IK:** N/A

**Location:** Damp

**IC:** No

**UL/ETL:** ETL

**FCC:** Yes

**RoHS:** Yes

**DLC:** 5.1 Premium

## OPTICAL FEATURES

Two beam patterns in one lens!

The standard lens 90° x 90° can be rotated 180° to convert to aisle beam 45° x 110° in seconds. No tools required!

**STANDARD: 90° X 90°**



**AISLE: 45° X 110°**



Whether your needs are to illuminate a wide open spaces or more narrow aisles, the Linear High Bay Pro has you covered.

## MOUNTING

**Standard:** 10' Suspension Cable V-Hook (Standard), Pendant (Optional), Surface (Optional)

## SIZING

WATTAGE	WIDTH	LENGTH	HEIGHT	WEIGHT
115W	11.02"	15.04"	2.22"	8.49 Lbs.
155W	11.02"	15.04"	2.22"	8.49 Lbs.
195W	12.01"	19.61"	2.46"	10.58 Lbs.
245W	12.01"	19.61"	2.46"	10.58 Lbs.
385W	13.39"	26.69"	2.46"	16.31 Lbs.

## ACCESSORIES

**Emergency Battery Back up  
Pluggable Sensors**

**Programming Remote Control  
Wire Guards**

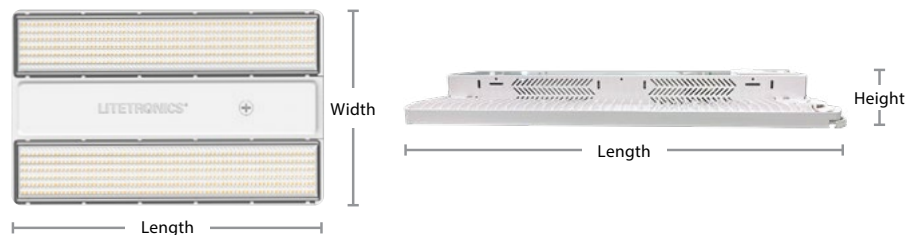

## PRODUCT OVERVIEW & INSTALLATION

**FIGURE A - SUSPENDING FIXTURE FROM A BEAM/RAFTER**

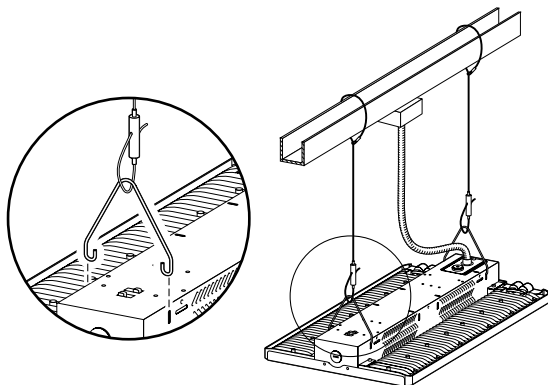

**FIGURE B - SENSOR INSTALLATION**

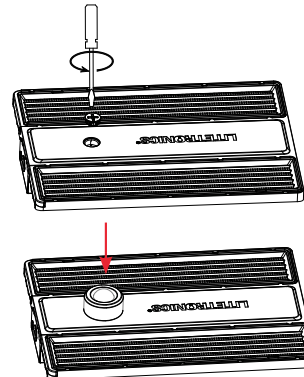

**Note:** If sensor (optional) is required, then use these compatible sensors SC005, SC006, SC008 (sold separately).

## ORDERING INFORMATION

Listed below are the max wattage settings and lumens for each model number.

LHBP115/LHBP155



LHBP195/LHBP245



LHBP385



ORDERING CODE	DESCRIPTION	WATTS	VOLTS	CCT (K)	LUMENS
LHBP115	115W Linear High Bay Pro 120-480V Watt and CCT Selectable with Sensor Socket	78   90   115	120-480V	4000K   5000K	12000   14000   18000
LHBP155	155W Linear High Bay Pro 120-480V Watt and CCT Selectable with Sensor Socket	78   115   155	120-480V	4000K   5000K	12000   18000   24000
LHBP195	195W Linear High Bay Pro 120-480V Watt and CCT Selectable with Sensor Socket	115   155   195	120-480V	4000K   5000K	18000   24000   30000
LHBP245	245W Linear High Bay Pro 120-480V Watt and CCT Selectable with Sensor Socket	185   225   245	120-480V	4000K   5000K	30000   36000   40000
LHBP385	385W Linear High Bay Pro 120-480V Watt and CCT Selectable with Sensor Socket	290   330   385	120-480V	4000K   5000K	45000   53000   61000

## EMERGENCY BATTERY BACKUP

### Emergency Battery Backup Compatibility (120-277V)\*

EMBB	115W	155W	195W	245W	385W
EB20*	Yes	Yes	Yes		Yes**
EB40*				Yes	Yes**

\* **Note:** The Linear High Bay Pro is rated 120-480V, emergency battery backup available for 120-277V only.

\*\* **Note:** It has two drivers of 195W. EB20 or EB40, should be hooked to one driver only.



ORDERING CODE	DESCRIPTION	USAGE
EB20*	20W Emergency Battery Backup (120-277V)	Supplies 90 minutes of battery backup to the fixture in times of a power outage. <ul style="list-style-type: none"> <li>This unit is compatible with fixtures using &gt;0W and ≤200W.</li> </ul> <b>Must be ordered with EBAM indicator module.</b>
EB40*	40W Emergency Battery Backup (120-277V)	Supplies 90 minutes of battery backup to the fixture in times of a power outage. <ul style="list-style-type: none"> <li>This unit is compatible with fixtures using &gt;0W and ≤300W.</li> <li>This unit is not currently compatible with sensor usage.</li> </ul>
EBAM	Adhesive-Mounted Indicator Module	This Adhesive-Mounted Indicator Module (EBAM) must be used with Litetronics' emergency battery backup product (EB20) to provide a visual confirmation of the operational status of the EBB unit. This module is typically used in open ceiling or drywall ceiling applications where the module is applied to the side of the fixture, mounting kit, or a nearby structural element.
TR01	Test Remote Control	Used for testing and demonstrating the functionality of EB20 emergency battery backup integrated products, sold separately.

## ACCESSORIES

### MOUNTS & GUARDS

ORDERING CODE	USAGE
LHBPA5SM	115W-245W LED Linear High Bay Pro surface mount accessory.
LHBPA5PM	115W-245W LED Linear High Bay Pro pendant mount accessory.
LHBPA5SM385	385W LED Linear High Bay Pro surface mount accessory. <b>(MTO Only)</b>
LHBPA5PM385	385W LED Linear High Bay Pro pendant mount accessory. <b>(MTO Only)</b>
LHBPAG51	Linear High Bay Pro wire guard 1.2 Ft. Compatible with LHBP115 & LHBP155.
LHBPAG52	Linear High Bay Pro Wire guard 1.6 Ft. Compatible with LHBP195 & LHBP245.

LHBPA5SM



LHBPA5PM



LHBPAG51

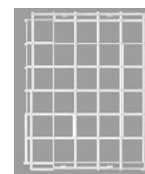

## SENSOR & CONTROL

ORDERING CODE	DESCRIPTION	USAGE
SC005	Plug-in PIR Sensor	Enable occupancy sensing and daylight harvesting on pluggable fixtures.
SC006	Plug-in Microwave Sensor	Enable occupancy sensing and daylight harvesting on pluggable fixtures. <b>(MTO Only)</b>
SCR053	Remote Control	Used (with SC005 and SC006 sensor) to adjust settings after installation.
SC008	Plug-in Bluetooth PIR Sensor with IR	This sensor enables wireless control of fixtures, or groups of fixtures, through the LiteSmart mobile app.
SCR054	Remote Control	Used to Commission LiteTronics "Next Generation" LiteSmart IR-Enabled Sensor SC008.



## BLUETOOTH CONTROL SWITCHES

MODEL #	DESCRIPTION	USAGE
BCS03	Bluetooth button battery powered wall switch	Used to control functionality of the fixture; on/off, dimming, daylight harvesting and scene selection. Dimensions: 1-1/4" width x 2 5/8" height x 1/2" depth.
BCS05	Bluetooth 7 Button AC Powered Wall Switch 120-277V	AC powered wall switch used to control functionality of the fixture; on/off, dimming and scene selection.



Note: Switches don't have CCT selectable capability.

## WIRELESS CONTROL WITH PLUGGABLE SENSORS



The optional MW (SC006 - made to order), and PIR Sensor (SC005) use a remote control for easy setup and control of individual fixtures.



The smart PIR sensor uses a remote control (SCR054) to Commission LiteTronics "Next Generation" LiteSmart IR-Enabled Sensor (SC008).



# LITESMART



LiteSmart is a mobile app that enables total management of lighting systems at the touch of your fingers. Within the app, all functionality can be set up and controlled; on/off, dimming, grouping, scene creation and time scheduling. Adjustments can also be made to the occupancy sensor and daylight harvesting settings, then implemented across an entire group in seconds.

- Total control over your lighting system
- Quick and easy changes that can be implemented in seconds across a group of fixtures
- Further energy reduction via occupancy sensing, daylight harvesting and max wattage control
- Ability to create custom scenes based on specific needs, such as presentations
- Time scheduling that sets hours of operation per day

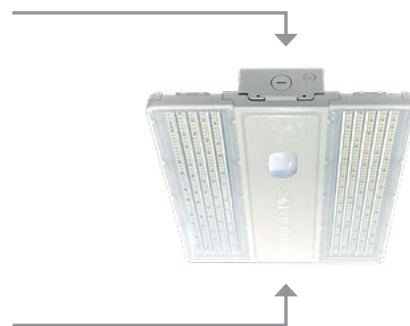

Set up and manage your space with LiteSmart. Use the remote switch for everyday control.