

PROJECT:	
CATALOG #	
TYPE:	DATE:

LED ROUND HIGH BAY - SL

SELECTABLE CCT & SELECTABLE WATTS

DESCRIPTION

The Litetronics LED High Bay SL with Selectable CCT and Selectable Watts is an affordable, direct replacement for HID fixtures that delivers an immediate reduction in energy costs while improving the consistency and quality of light within a space.

This lightweight and compact luminaire can be mounted directly to existing HID configurations, acting as a one-for-one replacement. Its 6' power cord provides plenty of length for wiring and the whole installation can be completed in a matter of minutes.

The fixture delivers 140 LPW with its 90° beam angle and circular light distribution provide even lighting throughout a space, increasing visual acuity and minimizing safety concerns.



FEATURES

- Up to 140 LPW
- Selectable CCT & Watts
- DLC 5.1 Premium
- IP65 with wet location rating
- 6kV surge protection
- Polycarbonate clear lens
- 0-10V dimming
- UL924 Compliant with 12V Sensor
- Hook mounting
- 6' power cord
- 5' safety cable
- 50,000-hour rated life
- 5-year warranty
- PIR all sensor available

MARKETS

- Retail
- Warehouse/storage
- Industrial
- Gymnasiums
- Garages
- High ceilings
- Task lighting

CERTIFICATIONS



SPECIFICATIONS

Life (@L70): 50,000 hours

Warranty: 5 years

PERFORMANCE

Operating temp: -22°F to 122°F (-30°C to 50°C)

Efficacy (LPW): 140

CRI: 80

ELECTRICAL

Input voltage: 120-277V **HV:** 277-480V

Input frequency: 50/60Hz

PF: ≥ 0.90

THD: < 20

Surge protection: > 6kV Surge protection

Dimming: 0-10V to off

Minimum dimming: N/A

Aux. Voltage: 12V

Driver CL: N/A

Whip/Cord: 6' (Input), 3' (Dim)

Sensor: Plug-In (Choice of MW, PIR, Bluetooth)

Safety rope: 1.6'

OPTICAL

Beam: 90°

Lens: Clear

UGR: < 28

PHYSICAL

Finish: Black

Heat Sink Color: Black

Housing: N/A

INDUSTRY STANDARDS/RATINGS

IP: 65

IK: 10

Location: Wet

IC: No

UL/ETL: UL, UL924 Compliant with 12V Sensor

FCC: Yes

RoHS: Yes

DLC: 5.1 Premium

MOUNTING

Standard: Round hook mounting

ACCESSORIES

Sensors SC005, SC006 and SC008

DIMENSIONS / WEIGHT

ORDER#	HEIGHT	DIAMETER	WEIGHT
HBS200B6	6.91"	13.07"	6.48 lbs.
HBS200B6HV	6.87"	13.07"	6.35 lbs.

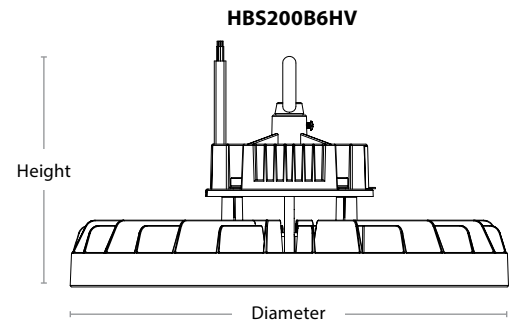
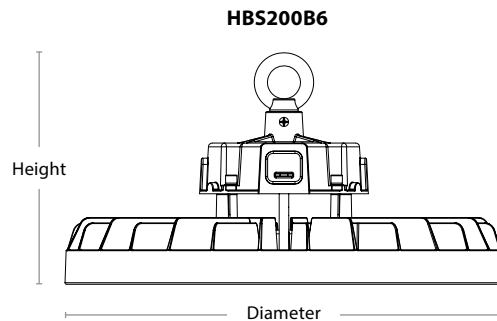

ORDERING INFORMATION

ORDERING CODE	DESCRIPTION	WATTAGE	VOLTS	CCT (K)	LUMENS
HBS200B6	100-200W LED Round High Bay Black 120-277V	100 150 200	120-277V	3500K 4000K 5000K	14000 21000 28000
HBS200B6HV	100-200W LED Round High Bay Black 277-480V	100 150 200	277-480V	3500K 4000K 5000K	14000 21000 28000



BCS03



BCS05

BLUETOOTH CONTROL SWITCHES

MODEL #	DESCRIPTION	USAGE
BCS02	Solar bluetooth control switch	Used to control functionality of the fixture; on/off, dimming, daylight harvesting and scene selection.
BCS03	Bluetooth button battery powered wall switch	Used to control functionality of the fixture; on/off, dimming, daylight harvesting and scene selection. Dimensions: 1-1/4" width x 2 5/8"height x 1/2"depth.

Note: Switches don't have CCT selectable capability.



SENSORS & CONTROLS

MODEL #	DESCRIPTION	USAGE
SC005	Plug-in PIR Sensor	Enable occupancy sensing and daylight harvesting on pluggable fixtures.
SC006	Plug-in Microwave Sensor	Enable occupancy sensing and daylight harvesting on pluggable fixtures.
SC008	Plug-in Bluetooth PIR Sensor with IR	This sensor enables wireless control of fixtures, or groups of fixtures, through the LiteSmart mobile app.
SCR053	Remote Control for plug-in PIR and Microwave sensors	Used to adjust sensor settings after installation, from the ground.
SCR054	Remote Control	Used to Commission LiteTronics "Next Generation" LiteSmart IR-Enabled Sensor.
HBSAM24	Yoke Mount	Yoke Mount for High Bay SL G3, black. (MTO only)
HBSAM22	Pendant Mount	Pendant Mount Accessory for High Bay SL.
HBAM31	Fixture hook with 3/4" pipe adapter	Connects directly to conduit via 3/4" threaded pipe, providing fixturing support.
EB20	20W Emergency Battery Backup	Supplies 90 minutes of battery backup to the fixture in times of a power outage.
EBCM	Ceiling-Mounted Indicator Module	This Ceiling-Mounted Indicator Module (EBCM) can be used with one of Litetronics' emergency battery backup products (EB10, EB10N or EB20) to provide a visual confirmation of the operational status of the EBB unit. This module is typically used in grid ceiling applications where it is recess mounted in a panel adjacent to the fixture.
EBAM	Adhesive-Mounted Indicator Module	This Adhesive-Mounted Indicator Module (EBAM) must be used with one of Litetronics' emergency battery backup products (EB10, EB10N or EB20) to provide a visual confirmation of the operational status of the EBB unit. This module is typically used in open ceiling or drywall ceiling applications where the module is applied to the side of the fixture, mounting kit, or a nearby structural element.
TR01	LED Emergency Light Test Remote	This accessory is required to operate and test the EMBB. <ul style="list-style-type: none"> • Only one remote required per area, building or site as necessary.

WIRELESS CONTROL WITH PLUGGABLE SENSORS



The optional MW (SC006 - made to order), and PIR Sensor (SC005) use a remote control for easy setup and control of individual fixtures.



The smart PIR sensor uses a remote control (SCR054) to Commission LiteTronics "Next Generation" LiteSmart IR-Enabled Sensor (SC008).



LITESMART



LiteSmart is a mobile app that enables total management of lighting systems at the touch of your fingers. Within the app, all functionality can be set up and controlled; on/off, dimming, grouping, scene creation and time scheduling. Adjustments can also be made to the occupancy sensor and daylight harvesting settings, then implemented across an entire group in seconds.

- Total control over your lighting system
- Quick and easy changes that can be implemented in seconds across a group of fixtures
- Further energy reduction via occupancy sensing, daylight harvesting and max wattage control
- Ability to create custom scenes based on specific needs, such as presentations
- Time scheduling that sets hours of operation per day



*Set up and manage your space with LiteSmart.
Use the remote switch for everyday control.*



WIRELESS SWITCH

Part #BCS03 or BCS05

The bluetooth control switch comes in handy for the daily occupants of a space. This switch, which can be wall mounted, enables quick adjustments to be made to a specific group of fixtures. Features include on/off, dimming, daylight harvesting and scene selection. The switch must be set up through the LiteSmart mobile app, but can then function on it's own within any space.

BENEFITS

- Control over key functions for a specific group of lights
- Adjustments are quick and easy, and create an optimized space for a variety of needs
- Further reduce energy via daylight harvesting function, or disable daylight harvesting for full brightness
- Ability to choose between custom scenes based on specific needs within the space

SWITCH CAPABILITIES

- Enable/disable auto daylight harvesting
- Brighten/dim a group or turn on/off the entire group of fixtures
- Program up to 3 scenes per switch